

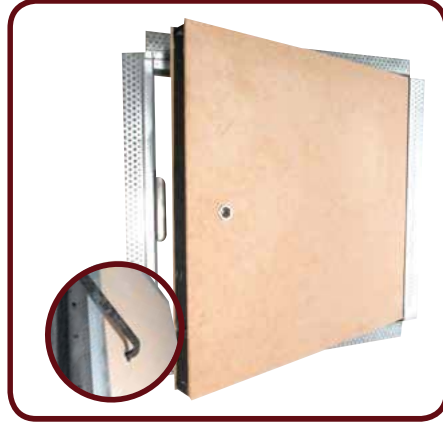

2 HOUR, CEILING, CONCEALED HINGE, ACCESS HATCH.



FEATHERED FLANGE



SETTING BEAD



CONCEALED HINGES

GENERAL

The Fyreguard 2 Hour CH - FYREHATCH is designed to provide a flush set or flanged fire rated access hatch for ceiling applications where access is required, while still maintaining at least a 2 hour fire rating. The 2 Hour CH - FYREHATCH sits flush with the ceiling lining and has concealed hinges to limit visual impact. The panel is secured by a rim lock with a key provided or can be individually keyed for maximum security.

USES

The 2 Hour CH -FYREHATCH is used in fire rated ceilings where access is required to ceiling cavity for service installations or maintainance.

SIZES

The maximum size is 700x700mm.

Stock sizes are: 300x300, 400x400, 450x450, 530x530 & 600x600mm

Non standard sizes are available on request.

FIRE TEST DATA

The 2 Hour CH - FYREHATCH has been tested and assessed to Australian Standard AS1530.4 to provide an FRL of -/120/60. Please contact your nearest Fyreguard office for further information.

KEY FEATURES

- **Product fit for purpose to meet the requirements of NCC (BCA)**
- **Ceiling application**
- **Simple Installation**
- **Australian Made**
- **Non Standard sizes available**
- **Flush fitting to Ceiling**
- **Concealed Hinges**

SPECIFICATION

Fyreguard 2 Hour CH - FYREHATCH FRL -/120/60 fire rated access hatch. Ceiling Application.
 PH. 07 55934955

INSTALLATION

Refer to following pages of this data sheet for installation instructions or contact your nearest Fyreguard office for assistance.

ARCHITECTURAL

Refer to following pages of this data sheet for dimensions of frame, profile and panel.



INSTALLATION INSTRUCTIONS

2 HOUR, CEILING HINGED, FIRE RATED ACCESS HATCH FIXING DETAIL:

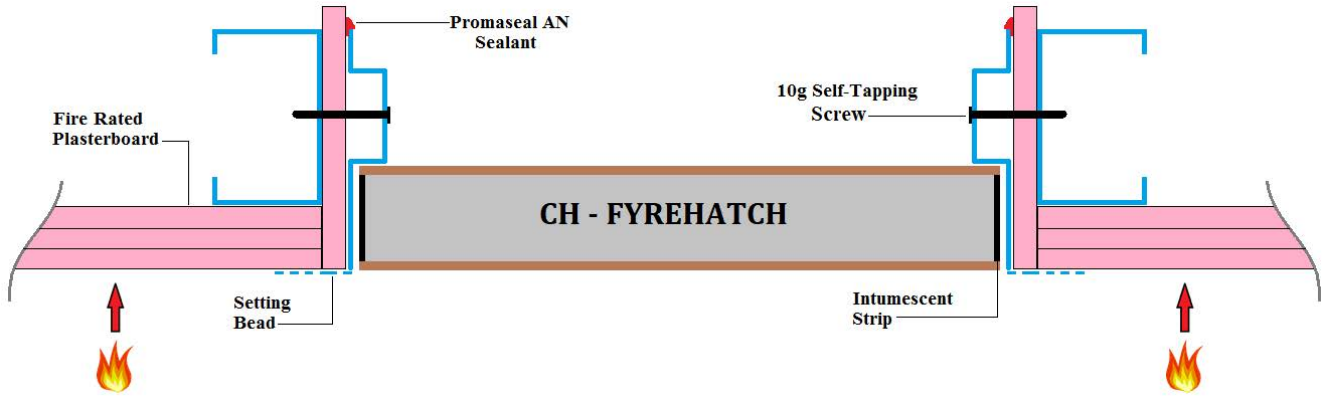

1. Mark out and cut opening in the ceiling. Trimmed opening to be 4mm Nom. larger than hatch required.
2. Frame opening with steel studs or trimmers. Ensure studs or trimmers are connected to joists or ceiling support system. Line the studs or trimmers with fire rated board of the same thickness as the fire exposed face.
3. Match access panel to the opening.
4. Open the hatch/panel and secure frame to the studs or trimmers with steel screws on all 4 sides of the hatch in the holes provided. For masonry installations use 60x6mm masonry anchors.
5. For 'Set Bead' installations remove the hatch/panel and flush set. Return hatch/panel into the frame and test operation. Ensure the hinge screws are tightened.
6. While the hatch/panel is open apply fire rated mastic sealant to any gaps between the access hatch frame and the inside reveal of the ceiling opening.
7. Close the hatch/panel and engage the lock.

ARCHITECTURAL DETAIL

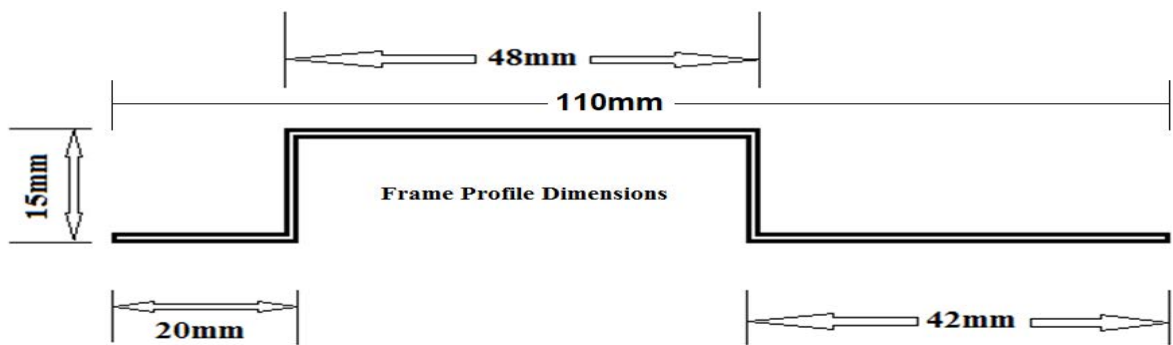

OPTIONAL FEATHERED FLANGE PROFILE.
(No Setting or Sanding Required)

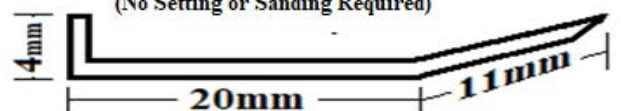

NB: ALL FYREGUARD FIRE RATED ACCESS HATCHES ARE LABELED FOR EASE OF COMPLIANCE AND MAINTAINENCE MAINTAINENCE INSPECTIONS. LABELING IS IN ACCORDANCEWITH FPAAGOOD PRACTICE GUIDE AND AS4072.1

NB: Fyreguard is not responsible if recipients of installation instructions, fire test reports or any relevant literature incorrectly interpret the contents or use products based on those interpretations.



INSTALLATION INSTRUCTIONS

2 HOUR, CEILING HINGED, FIRE RATED ACCESS HATCH FIXING DETAIL:

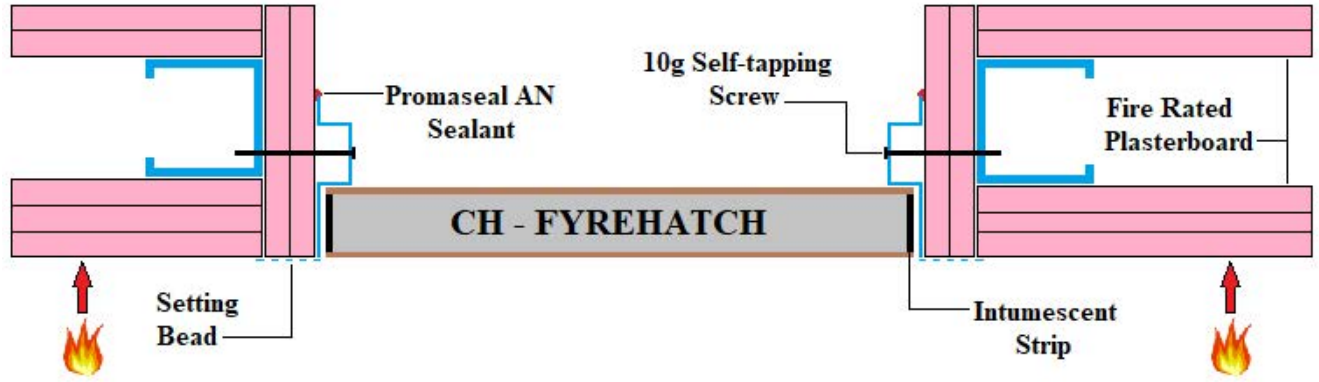

1. Mark out and cut opening in the ceiling. Trimmed opening to be 4mm Nom. larger than hatch required.
2. Frame opening with steel studs or trimmers. Ensure studs or trimmers are connected to joists or ceiling support system. Line the studs or trimmers with fire rated board of the same thickness as the fire exposed face.
3. Match access panel to the opening.
4. Open the hatch/panel and secure frame to the studs or trimmers with steel screws on all 4 sides of the hatch in the holes provided. For masonry installations use 60x6mm masonry anchors.
5. For 'Set Bead' installations remove the hatch/panel and flush set. Return hatch/panel into the frame and test operation. Ensure the hinge screws are tightened.
6. While the hatch/panel is open apply fire rated mastic sealant to any gaps between the access hatch frame and the inside reveal of the ceiling opening.
7. Close the hatch/panel and engage the lock.

ARCHITECTURAL DETAIL

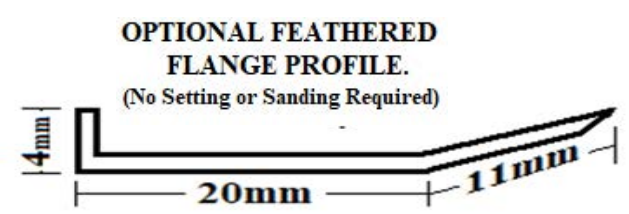
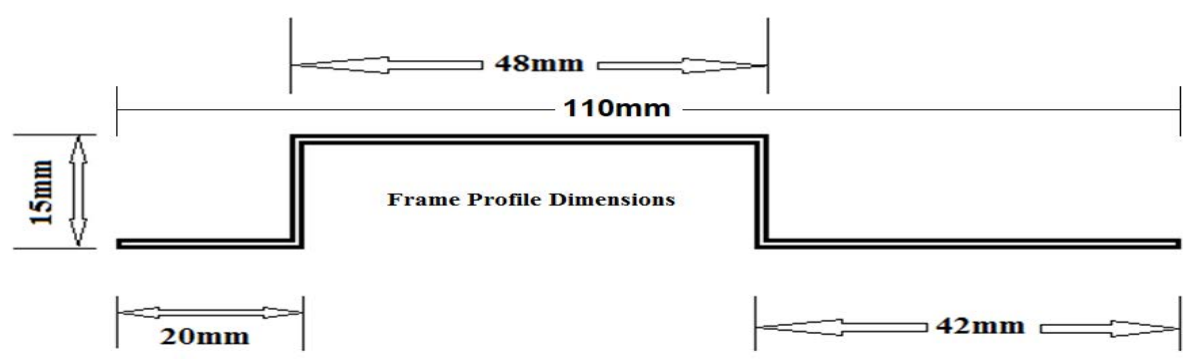

NB: ALL FYREGUARD FIRE RATED ACCESS HATCHES ARE LABELED FOR EASE OF COMPLIANCE AND MAINTAINENCE MAINTAINENCE INSPECTIONS. LABELING IS IN ACCORDANCEWITH FPA GOOD PRACTICE GUIDE AND AS4072.1
NB: Fyreguard is not responsible if recipients of installation instructions, fire test reports or any relevant literature incorrectly interpret the contents or use products based on those interpretations.



INSTALLATION INSTRUCTIONS

2 HOUR, CEILING HINGED, FIRE RATED ACCESS HATCH FIXING DETAIL:

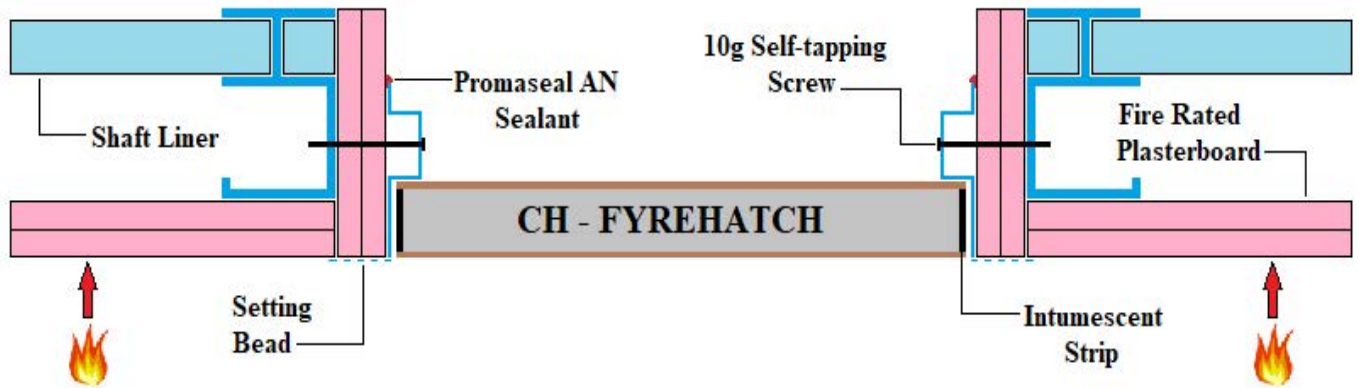

1. Mark out and cut opening in the ceiling. Trimmed opening to be 4mm Nom. larger than hatch required.
2. Frame opening with steel studs or trimmers. Ensure studs or trimmers are connected to joists or ceiling support system. Line the studs or trimmers with fire rated board of the same thickness as the fire exposed face.
3. Match access panel to the opening.
4. Open the hatch/panel and secure frame to the studs or trimmers with steel screws on all 4 sides of the hatch in the holes provided. For masonry installations use 60x6mm masonry anchors.
5. For 'Set Bead' installations remove the hatch/panel and flush set. Return hatch/panel into the frame and test operation. Ensure the hinge screws are tightened.
6. While the hatch/panel is open apply fire rated mastic sealant to any gaps between the access hatch frame and the inside reveal of the ceiling opening.
7. Close the hatch/panel and engage the lock.

ARCHITECTURAL DETAIL

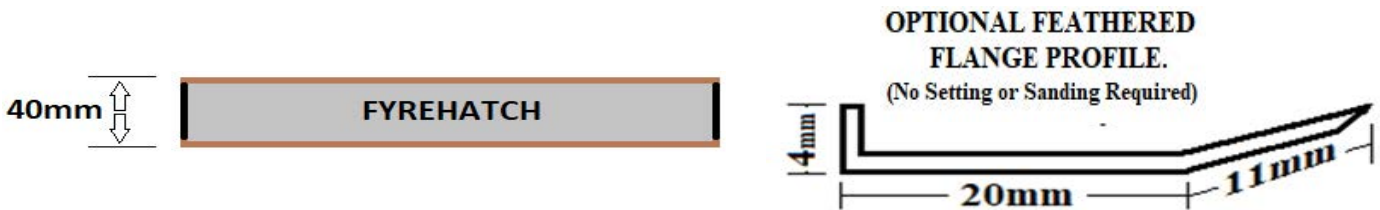
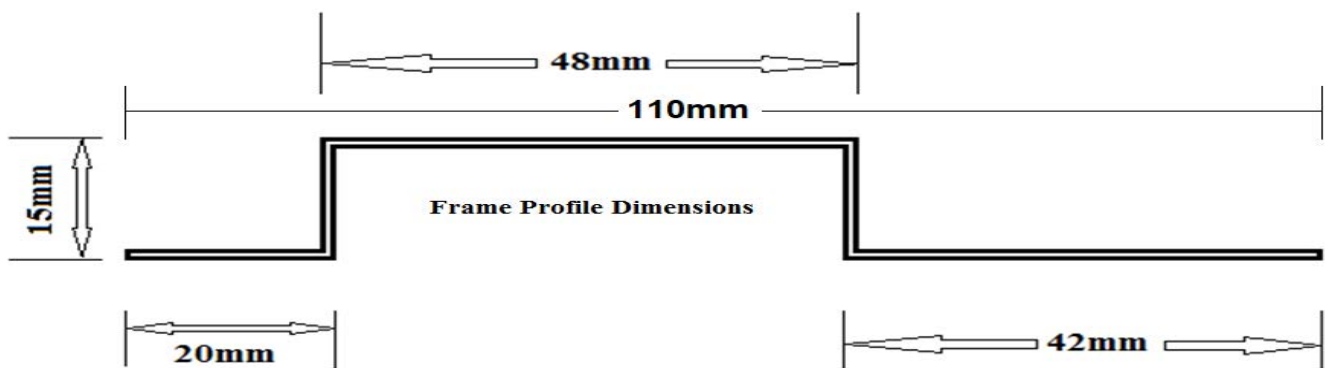

NB: ALL FYREGUARD FIRE RATED ACCESS HATCHES ARE LABELED FOR EASE OF COMPLIANCE AND MAINTAINENCE MAINTAINENCE INSPECTIONS. LABELING IS IN ACCORDANCE WITH FPAA GOOD PRACTICE GUIDE AND AS4072.1

NB: Fyreguard is not responsible if recipients of installation instructions, fire test reports or any relevant literature incorrectly interpret the contents or use products based on those interpretations.



INSTALLATION INSTRUCTIONS

2 HOUR, CEILING HINGED, FIRE RATED ACCESS HATCH FIXING DETAIL:

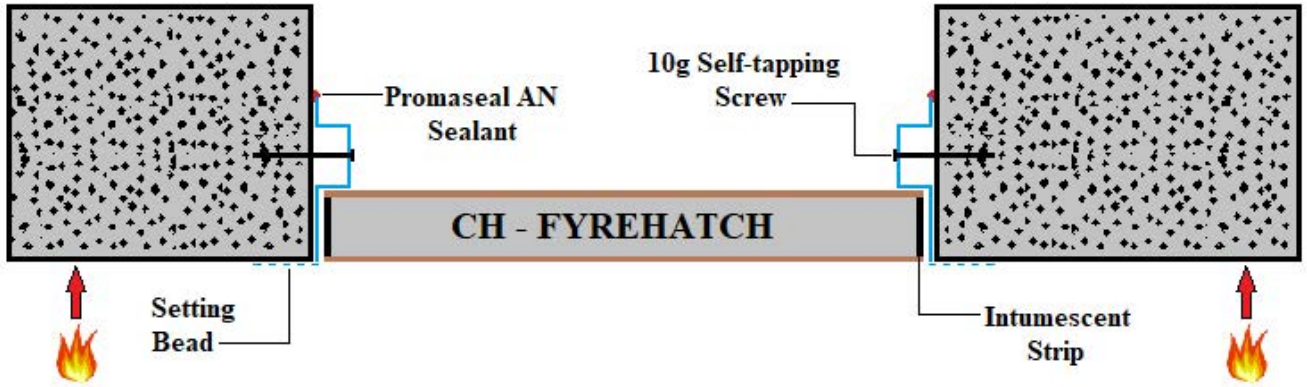

1. Mark out and cut opening in the ceiling. Trimmed opening to be 4mm Nom. larger than hatch required.
2. Frame opening with steel studs or trimmers. Ensure studs or trimmers are connected to joists or ceiling support system. Line the studs or trimmers with fire rated board of the same thickness as the fire exposed face.
3. Match access panel to the opening.
4. Open the hatch/panel and secure frame to the studs or trimmers with steel screws on all 4 sides of the hatch in the holes provided. For masonry installations use 60x6mm masonry anchors.
5. For 'Set Bead' installations remove the hatch/panel and flush set. Return hatch/panel into the frame and test operation. Ensure the hinge screws are tightened.
6. While the hatch/panel is open apply fire rated mastic sealant to any gaps between the access hatch frame and the inside reveal of the ceiling opening.
7. Close the hatch/panel and engage the lock.

ARCHITECTURAL DETAIL

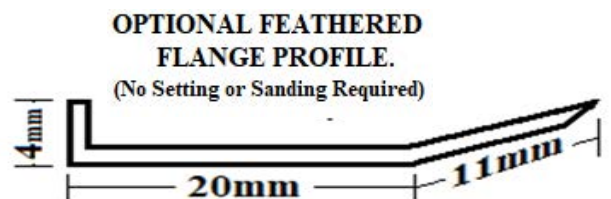
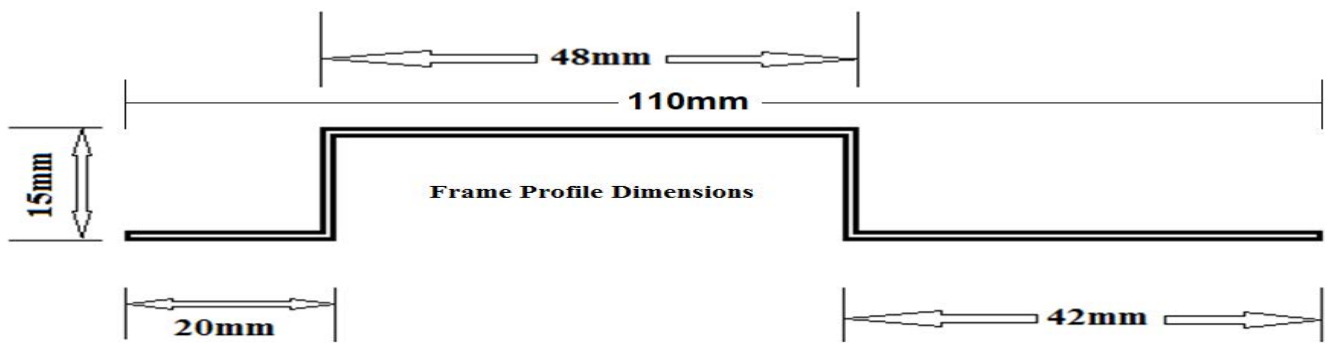

NB: ALL FYREGUARD FIRE RATED ACCESS HATCHES ARE LABELED FOR EASE OF COMPLIANCE AND MAINTAINENCE MAINTAINENCE INSPECTIONS. LABELING IS IN ACCORDANCEWITH FPAA GOOD PRACTICE GUIDE AND AS4072.1