

FWH PROMASEAL® Floor Waste Collar (High Profile Cast-in Type) Installation Instruction

Floor waste collars help prevent the passage of fire and smoke through openings in compartment floors in the event of a fire. For installation of collars on permanent form work and in thin floor slabs (<150mm) always contact Promat. These collars are available in various models and the type used depends on the certification required for the building.

FWH PROMASEAL® High Profile Cast-in Floor Waste Collars are designed to provide fire resistance where floor wastes penetrate wet areas. The collars have been tested for cast-in floor applications and when tested to AS1530: Part 4 and AS4072: Part 1 achieved an FRL of -/180/180.

The FWH 100 type is suitable for 100mm and 80mm uPVC and 100mm HDPE pipe. The FWH 50 type is suitable for 50mm uPVC pipe.

Tested slab depth is 150mm.

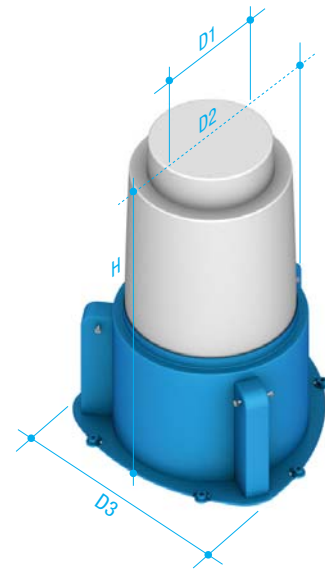
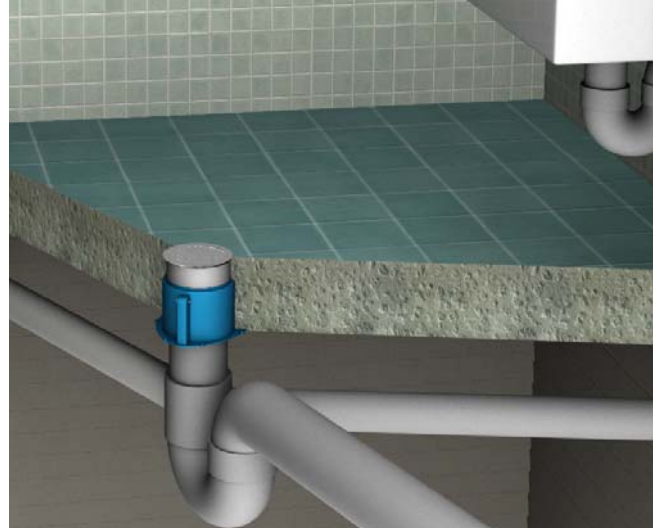

Installation Method

Nail or screw the collar to the formwork through the breakaway holders at the edge of the collar. Once the concrete has been poured cut off the rest of the collar level with the top of the concrete floor.

Once the floor waste system has been installed from below, there may be a gap between the outside of the pipe and the collar. This gap should be sealed with a bead of fire resistant sealant at a depth of at least 10mm.

The plastic triangular spacer at the bottom of the collar has plastic location points to assist with keeping the pipe in vertical position.

Typical Specification

Where plastic pipes used for floor wastes are to be fire rated, use FWH PROMASEAL® High Profile Cast-in Floor Waste Collars as tested to AS1530: Part 4 and AS4072: Part 1 to maintain the required FRL of the element. All details to be in accordance with the manufacturers' instructions. All work to be certified in an approved manner.

Dimensions Guide

Code no.	uPVC pipe nominal (mm)	HDPE pipe nominal (mm)	Body (mm)		Flange (mm)	
			H	D1	D2	D3
FWH 50	50	–	178	55	125	132
	80	–	270	108	186	190
FWH 100	100	100				

Promat provides a wide range of systems for compartmentation, fire rated air and cable ducts, structural steel protection, fire stopping and partitions.

For assistance with any ProActive Fire Protection problems, contact your local distributor.

Promat Asia Pacific Organisations

- AUSTRALIA +61 1800 PROMAT
- INDIA +91 (11) 2577 8413

- CHINA +86 (20) 8136 1167 / +86 (10) 8589 1254
- MALAYSIA +60 (3) 2095 8555

- SINGAPORE +65 6776 7635

- HONG KONG +852 2836 3692
- VIETNAM +84 (8) 931 5964

an **etex** GROUP company