

Four sided channel fixing

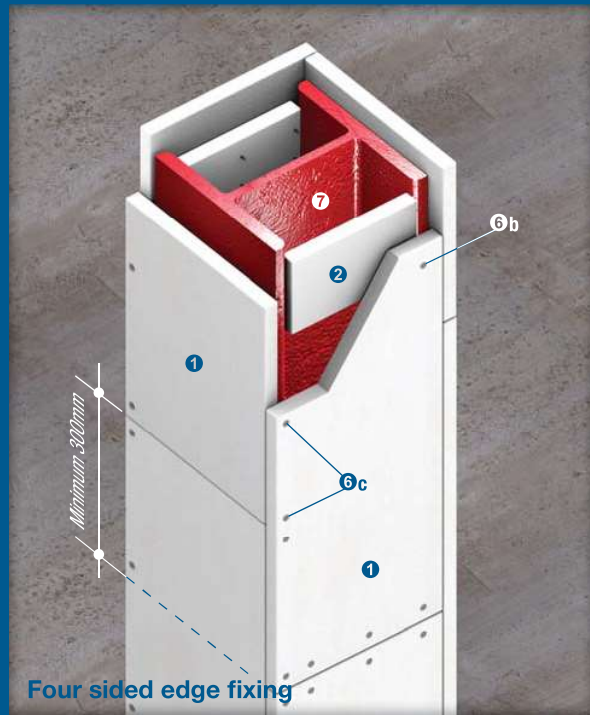

Four sided edge fixing

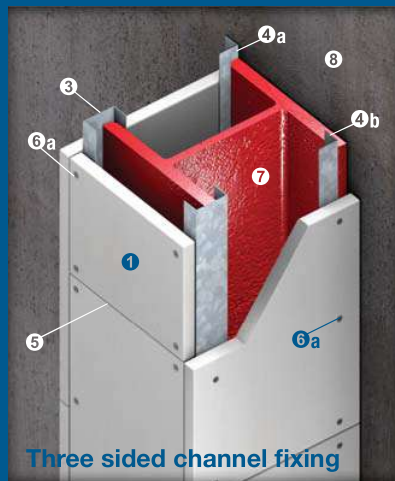

Three sided channel fixing



Three sided edge fixing

Up to 150/-/- fire resistance in accordance with the requirements of AS 1530: Part 4: 2005

- ① PROMATECT® 100 board, thickness in accordance with the Hp/A Ratio tables on page 46
- ② PROMATECT® 100 soldiers 100mm wide, minimum thickness similar to the board thickness of ①
- ③ Continuous galvanised steel channel 19mm x 38mm x 19mm x 0.8mm thick or similar, leg of each channel is located against inner surface of flange
- ④a Continuous galvanised steel angles minimum 32mm x 19mm x 0.8mm thick or similar fixed to the wall using non combustible proprietary anchors at nominal 500mm centres
- ④b Continuous galvanised steel angles minimum 32mm x 19mm x 0.8mm thick or similar fixed to the flange using Tek screws, shot fired nails or welding. Secure edges of side boards at 200mm centres
- ⑤ Horizontal joints in adjacent board sides to be staggered at minimum 300mm
For wide columns, it is advisable to include a PROMATECT® 100 cover strip behind the joints within the web of the steel column to provide additional impact resistance
- ⑥a Self-drilling or self-tapping drywall screws fixed to channel/angle at nominal 200mm centres. Screw length should be additional 20mm of the board thickness
- ⑥b Self-drilling or self-tapping drywall screws fixed to soldiers at nominal 100mm centres. Screw length should be additional 20mm of the board thickness
- ⑥c Steel wire staple fixing in accordance with table below. When edge fixing it is advisable to drill pilot holes, particularly with 15mm thick boards. Please consult Promat for further guidance

PROMATECT® 100 board thickness	Steel wire staples at 100mm centres
15mm	44/10/1mm
20mm	44/10/1mm
25mm	50/10/1mm
30mm	60/10/1mm

- ⑦ Structural steel column
- ⑧ Concrete wall substrate



Three sided channel fixing

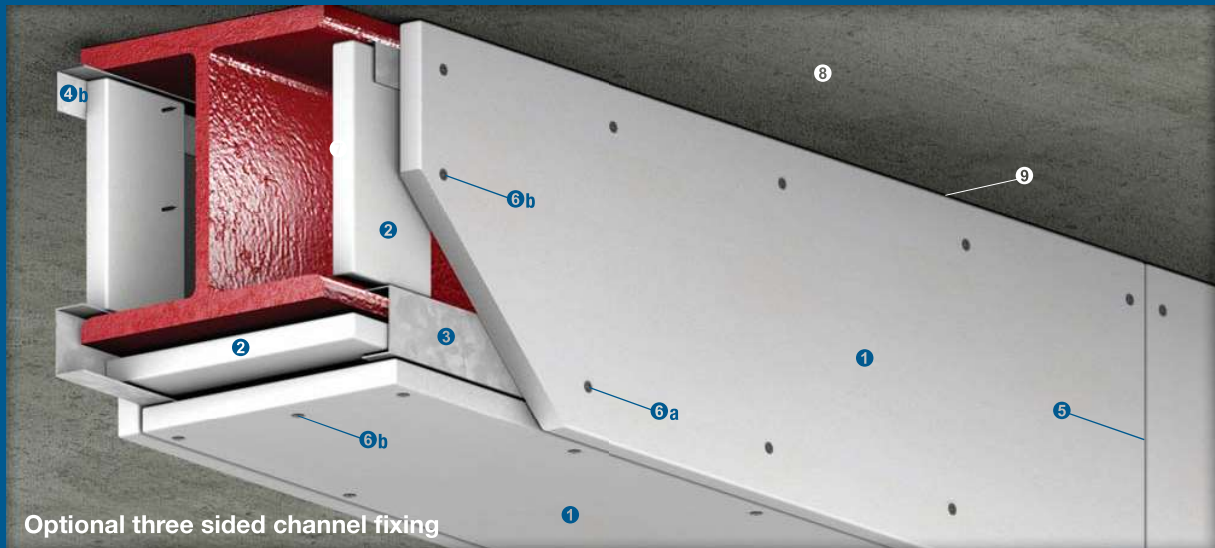

Optional three sided channel fixing

Up to 150/-/- fire resistance in accordance with the requirements of AS 1530: Part 4: 2005

- ❶ PROMATECT® 100 board, thickness in accordance with the Hp/A Ratio tables on page 46
- ❷ PROMATECT® 100 soldiers 100mm wide, minimum thickness similar to the board thickness of ❶, fixed within the web of the steel beam at maximum 1220mm centres behind the board joints using screws at 100mm centres or using staples at 50mm centres
For deep beams clad with thicker boards for greater fire resistance, it is advisable to fix the soldiers at nominal 600mm centres in order to reduce the load on the soldiers. For steel beams greater than 600mm deep, a T-section soldier should be used to provide a stronger support
- ❸ Continuous galvanised steel channel 19mm x 38mm x 19mm x 0.8mm thick or similar located at the bottom flange, leg of each channel is facing inner surface of the flange
- ❹a Continuous galvanised steel angles minimum 32mm x 19mm x 0.8mm thick or similar fixed to the floor slab using non combustible proprietary anchors at nominal 500mm centres

- ❹b Continuous galvanised steel angles minimum 32mm x 19mm x 0.8mm thick or similar beneath the upper flange
- ❺ Vertical and horizontal joints in adjacent board sides to be staggered at minimum 300mm
- ❺a Self-drilling or self-tapping drywall screws fixed to channel/angle at nominal 200mm centres. Screw length should be additional 20mm of the board thickness
- ❺b Self-drilling or self-tapping drywall screws fixed to soldiers at nominal 100mm centres. Screw length should be additional 20mm of the board thickness
- ❷ Structural steel beam
- ❸ Floor slab
- ❹ Caulk all edges between the board and the floor slab with PROMASEAL®-A Acrylic Sealant, depth in accordance with the required board thickness

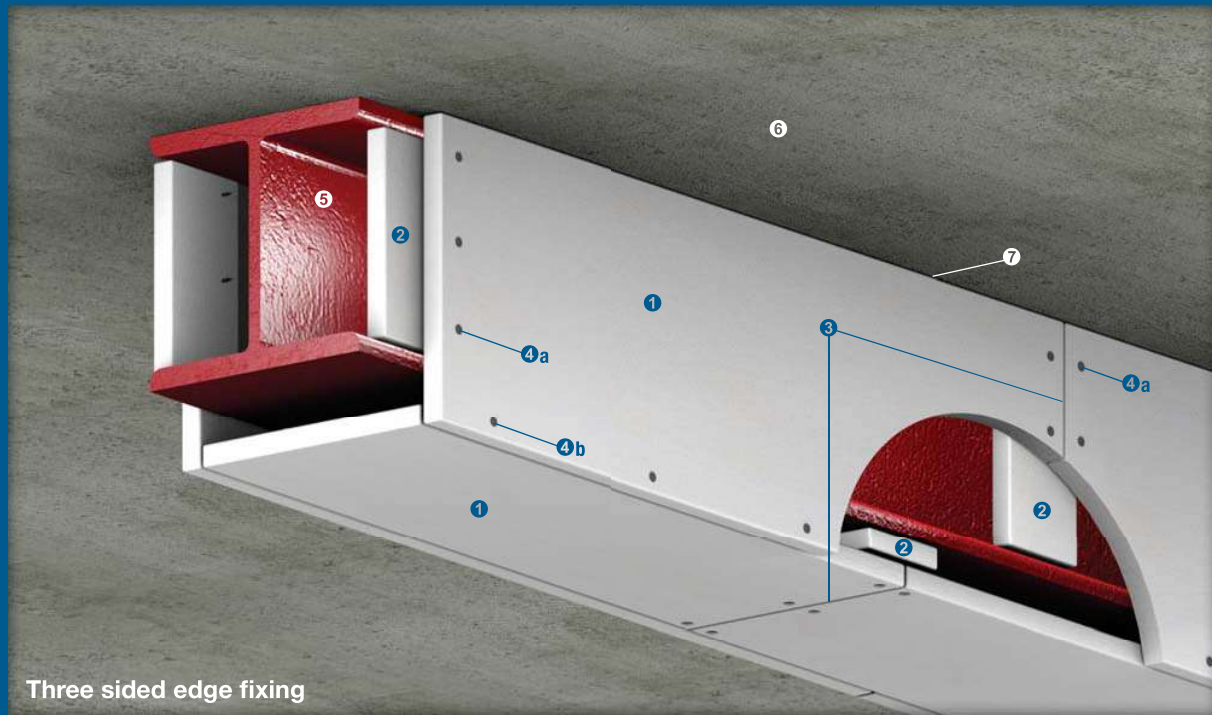

Three sided edge fixing

Up to 150/-/- fire resistance in accordance with the requirements of AS 1530: Part 4: 2005

- ❶ PROMATECT® 100 board, thickness in accordance with the Hp/A Ratio tables on page 46
- ❷ PROMATECT® 100 soldiers 100mm wide, minimum thickness similar to the board thickness of ❶, fixed within the web of the steel beam at maximum 1220mm centres behind the board joints using screws at 100mm centres or using staples at 50mm centres

For deep beams clad with thicker boards for greater fire resistance, it is advisable to fix the soldiers at nominal 600mm centres in order to reduce the load on the soldiers. For steel beams greater than 600mm deep, a T-section soldier should be used to provide a stronger support
- ❸ Vertical and horizontal joints in adjacent board sides to be staggered at minimum 300mm
- ❹a Self-drilling or self-tapping drywall screws fixed to soldiers at nominal 100mm centres. Screw length should be additional 20mm of the board thickness
- ❹b Steel wire staple fixing in accordance with table below. When edge fixing it is advisable to drill pilot holes, particularly with 15mm thick boards. Please consult Promat for further guidance

PROMATECT® 100 board thickness	Steel wire staples at 100mm centres
15mm	44/10/1mm
20mm	44/10/1mm
25mm	50/10/1mm
30mm	60/10/1mm

- ❺ Structural steel beam
- ❻ Floor slab
- ❼ Caulk all edges between the board and the floor slab with PROMASEAL®-A Acrylic Sealant, depth in accordance with the required board thickness

The following is a standard Architectural Specification for structural steel column and beam protection using PROMATECT® 100. Please note that PROMATECT® 100 can be installed by using either screw or staple type of edge fixing. The end user must determine the suitability of any particular design to meet the performance requirements of any application before undertaking any work. If in doubt, please first obtain the advice from a suitably qualified engineer.

The installation methods described herein are suitable for steel sections up to 686mm deep and 325mm wide. For larger section or when protecting multiple sections within a single encasement, please consult Promat.

Where a column box encasement abuts a beam protected with a profiled fire protection system, e.g. intumescent paint, the column webs should be sealed at their tops using PROMATECT® 100.

Fire Exposure & Area of Application

Exposed faces of steelwork internal to building, for up to 150 minute fire resistance in accordance with the requirements of AS 1530: Part 4: 2005.

Location

(1)

Type of Construction

_____ minute⁽²⁾ fire resistance to PROMATECT® 100 one sided, two sided, three sided or four sided encasement of structural steel columns and beams.

Lining Boards

_____mm⁽³⁾ thick PROMATECT® 100 PromaX® mineral boards as manufactured by Promat International (Asia Pacific) Ltd, in size _____mm x _____mm⁽⁴⁾, cut to size on-site/pre cut in accordance with the schedule of sizes⁽⁵⁾ and fixed in accordance with the manufacturer's recommended details and fixing instructions.

Screw Fixing

COLUMNS

PROMATECT® 100 boards to be fixed by board face to board edge using _____mm^(6a) self-drilling, self-tapping screws at nominal 200mm centres.

BEAMS

Vertical PROMATECT® 100 boards to be screwed to 100mm wide x _____mm⁽³⁾ thick PROMATECT® 100 soldiers wedged between flanges at 1200mm centres using _____mm^(6a) self-drilling, self-tapping screws at nominal 100mm centres.

Where mechanical fixing is required for columns or beams, PROMATECT® 100 boards to be fixed by board face to board edge using _____mm^(6a) self-drilling, self-tapping screws at nominal 200mm centres to nominal 19mm x 38mm x 19mm x 0.8mm continuous pressed steel channels or similar at bottom steel flange AND to 32mm x 19mm x 0.8mm continuous pressed steel angles secured to soffit of floor/roof slab or top steel flange. The angles should be fixed at nominal 500mm centres.

Staple Fixing

COLUMNS

PROMATECT® 100 boards to be fixed by board face to board edge using _____mm^(6b) staples at nominal 100mm centres.

BEAMS

Vertical PROMATECT® 100 boards to be screwed to 100mm wide x _____mm⁽³⁾ thick PROMATECT® 100 soldiers wedged between flanges at 1200mm centres using _____mm^(6b) staples at nominal 50mm centres.

Continued on next page

Continued from previous page

Butt Jointing For Screw Fixing

For beam casings only, PROMATECT® 100 board joints in the soffit to be backed with 100mm wide x minimum _____mm⁽³⁾ thick PROMATECT® 100 internal cover strips secured with _____mm⁽⁷⁾ self-drilling, self-tapping screws at nominal 100mm centres.

Butt Jointing For Staple Fixing

For beam casings only, PROMATECT® 100 board joints in the soffit to be backed with 100mm wide x minimum _____mm⁽³⁾ thick PROMATECT® 100 internal cover strips secured with _____mm⁽⁷⁾ staples to one side of board joint only.

Follow-on Trades

Surface of boards to be prepared for painting/plastering/tiling⁽⁶⁾ in accordance with manufacturer's recommendations.

NOTE:

- ⁽¹⁾ insert location, e.g. "beams and columns to offices interior", or provide steelwork drawing reference.
- ⁽²⁾ insert required fire resistance level not exceeding 150 minutes.
- ⁽³⁾ insert required thickness by reference to section factor (Hp/A) and fire resistance level.
- ⁽⁴⁾ select board size on basis of economy in cutting. Standard board size is 2500mm x 1200mm.
- ^{(5), (8)} delete as appropriate.
- ^(6a) insert screw length which gives minimum 25mm penetration having regard to encasement thickness.
- ^(6b) insert staple length which gives minimum 25mm penetration having regard to encasement thickness.
- ⁽⁷⁾ insert screw length which is minimum 5mm longer than twice the encasement thickness.

Hp/A Ratio Table 1 Up to 150/-/- fire resistance in accordance with the requirements of **AS 1530: Part 4: 2005** (report no. BRANZ FAR 3015) for **structural steel column protection at critical temperature of 550°C**

Fire resistance	PROMATECT® 100 board thickness (mm)					
	15	20	25	30 (15 x 2 layers)	35 (20 + 15, 1 layer each)	40 (20 x 2 layers)
30 minutes	260	260	260	260	260	260
60 minutes	260	260	260	260	260	260
90 minutes	114	185	260	260	260	260
120 minutes	68	102	145	201	260	260
150 minutes	—	70	96	126	163	190

Hp/A Ratio Table 2 Up to 150/-/- fire resistance in accordance with the requirements of **AS 1530: Part 4: 2005** (report no. BRANZ FAR 3015) for **structural steel beam protection at critical temperature of 550°C**

Fire resistance	PROMATECT® 100 board thickness (mm)					
	15	20	25	30 (15 x 2 layers)	35 (20 + 15, 1 layer each)	40 (20 x 2 layers)
30 minutes	260	260	260	260	260	260
60 minutes	260	260	260	260	260	260
90 minutes	102	162	249	260	260	260
120 minutes	—	92	129	176	238	260
150 minutes	—	—	87	114	146	168

Hp/A Ratio Table 3 Up to 150/-/- fire resistance in accordance with the requirements of **AS 1530: Part 4: 2005** (report no. BRANZ FAR 3015) for **structural steel beam protection at critical temperature of 620°C**

Fire resistance	PROMATECT® 100 board thickness (mm)					
	15	20	25	30 (15 x 2 layers)	35 (20 + 15, 1 layer each)	40 (20 x 2 layers)
30 minutes	260	260	260	260	260	260
60 minutes	260	260	260	260	260	260
90 minutes	115	232	249	260	260	260
120 minutes	—	94	149	243	260	260
150 minutes	—	—	85	120	171	213

For single layer application of ≥30mm thick PROMATECT® 100 board, please consult Promat.