

# TRAFALGAR



## **MaxiLite** FIRE RATED BULK HEAD SYSTEMS

UTILISING LIGHTWEIGHT 60mm BOARD

Up to 4 hours Fire Ratings  
(to AS 1530.4-2005)

## Horizontal one-sided bulkheads

60mm thick Maxilite boards, up to 1500mm wide



### Self-supporting system

**FRL**  
-/240/240  
Fire from both directions

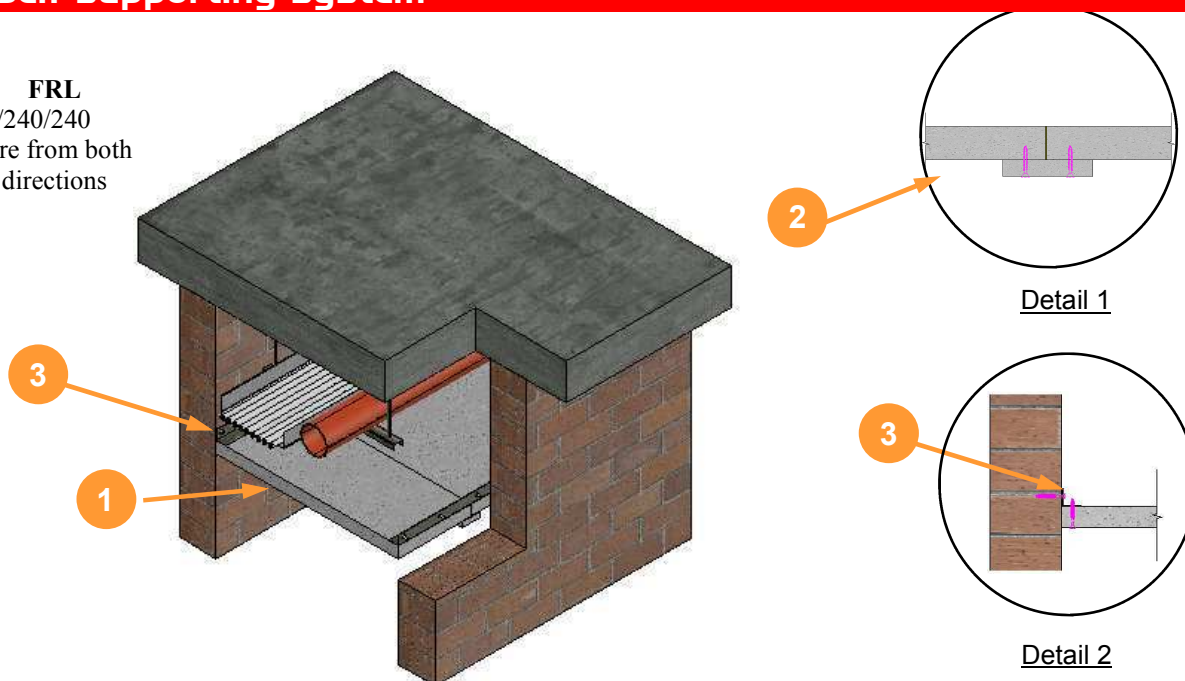

**Key:**

- 1 Maxilite boards, 60mm thick (or equivalent laminated thickness)
- 2 Cover Strips (Detail 1)
- 3 Steel angles, 50mm x 50mm x 0.8mm (Detail 2)
- 4 Butt joint

<b>Maxilite board</b>	60mm thick board for 4 hour fire rating. Boards are joined together using rebate or butt joints incorporating approved fire rated sealant in all joints. Boards are screw-fixed to steel angles at max. 200mm centres.
<b>Corners</b>	Corners fixed to steel angles with self tapping screws at 200mm centres.
<b>Joints</b>	Boards are joined by butt joints incorporating approved fire rated sealant. Cover strips are fixed over the joint.
<b>Cover strips</b>	20 or 30mm Maxilite or 9mm Orbit FR x 100mm wide fixed to outside of joint. Strips are secured to both sides of the joint at max. 200mm centres.
<b>Steel angles</b>	50mm x 50mm x 0.8mm (minimum size), fixed to masonry, concrete or plasterboard at max. 600mm centres and screw-fixed to boards.
<b>Fixings</b>	<ul style="list-style-type: none"> <li>- Board to board / steel angle: minimum M4 - 100mm self tapping screws at 200mm centres. Allow 10 to 15mm from edges of Maxilite board.</li> <li>- Steel angle to masonry or concrete: minimum M6 anchor bolts at 400mm centres.</li> <li>- Steel angle to plasterboard: minimum M4 - 100mm self tapping screws at 400mm centres.</li> </ul>

**Note:** Laminated boards of equivalent thickness can be used. I.e. 2x30mm

BULKHEAD — HORIZONTAL

## Horizontal two-sided bulkheads

60mm thick Maxilite boards, up to 1500mm x 1500mm



### Self-supporting system

**FRL**  
-/240/240  
Fire from both directions

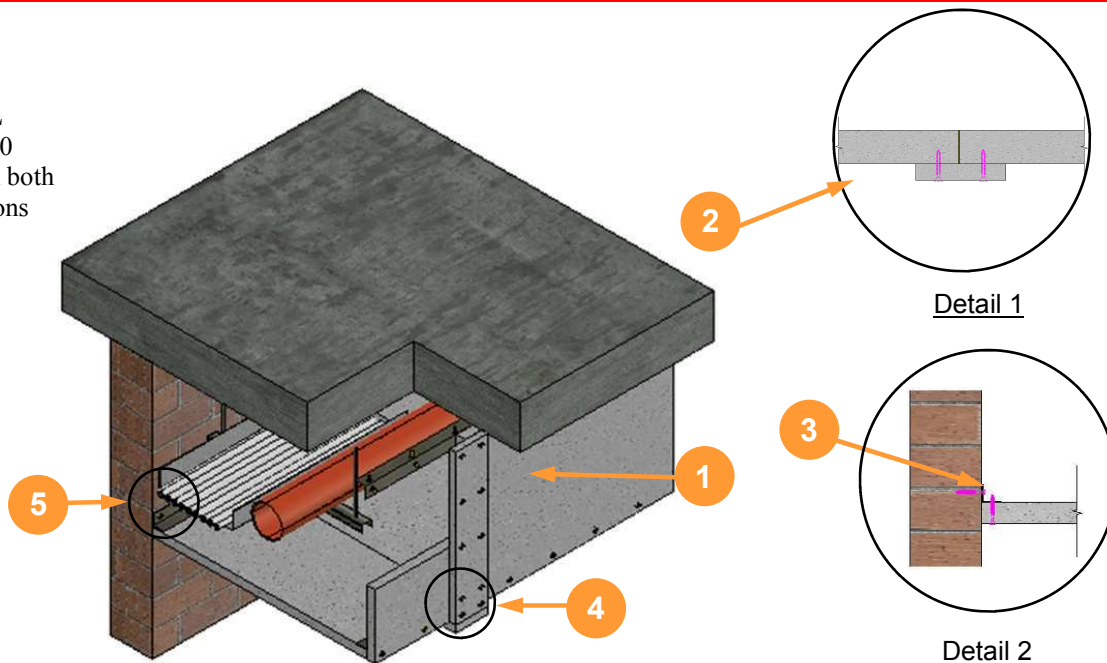

**Key:**

- 1 Maxilite boards, 60mm thick (or equivalent laminated thickness)
- 2 Cover Strips (Detail 1)
- 3 Steel angles, 50mm x 50mm x 0.8mm (Detail 2)
- 4 Butt joint

<b>Maxilite board</b>	60mm thick board for 4 hour fire rating. Boards are joined together using rebate or butt joints incorporating approved fire rated sealant in all joints. Boards are screw-fixed to steel angles at max. 200mm centres.
<b>Corners</b>	Corners fixed to steel angles with self tapping screws at 200mm centres.
<b>Joints</b>	Boards are joined by butt joints incorporating approved fire rated sealant. Cover strips are fixed over the joint.
<b>Cover strips</b>	20 or 30mm Maxilite or 9mm Orbit FR x 100mm wide fixed to outside of joint. Strips are secured to both sides of the joint at max. 200mm centres.
<b>Steel angles</b>	50mm x 50mm x 0.8mm (minimum size), fixed to masonry, concrete or plasterboard at max. 600mm centres and screw-fixed to boards.
<b>Fixings</b>	<ul style="list-style-type: none"> <li>- Board to board / steel angle: minimum M4 - 100mm self tapping screws at 200mm centres. Allow 10 to 15mm from edges of Maxilite board.</li> <li>- Steel angle to masonry or concrete: minimum M6 anchor bolts at 400mm centres.</li> <li>- Steel angle to plasterboard: minimum M4 - 100mm self tapping screws at 400mm centres.</li> </ul>

**Note:** Laminated boards of equivalent thickness can be used. I.e. 2x30mm

**BULKHEAD — HORIZONTAL**

## Horizontal three-sided bulkhead

60mm thick Maxilite boards, up to 1500mm x 1500mm



### Self-supporting system

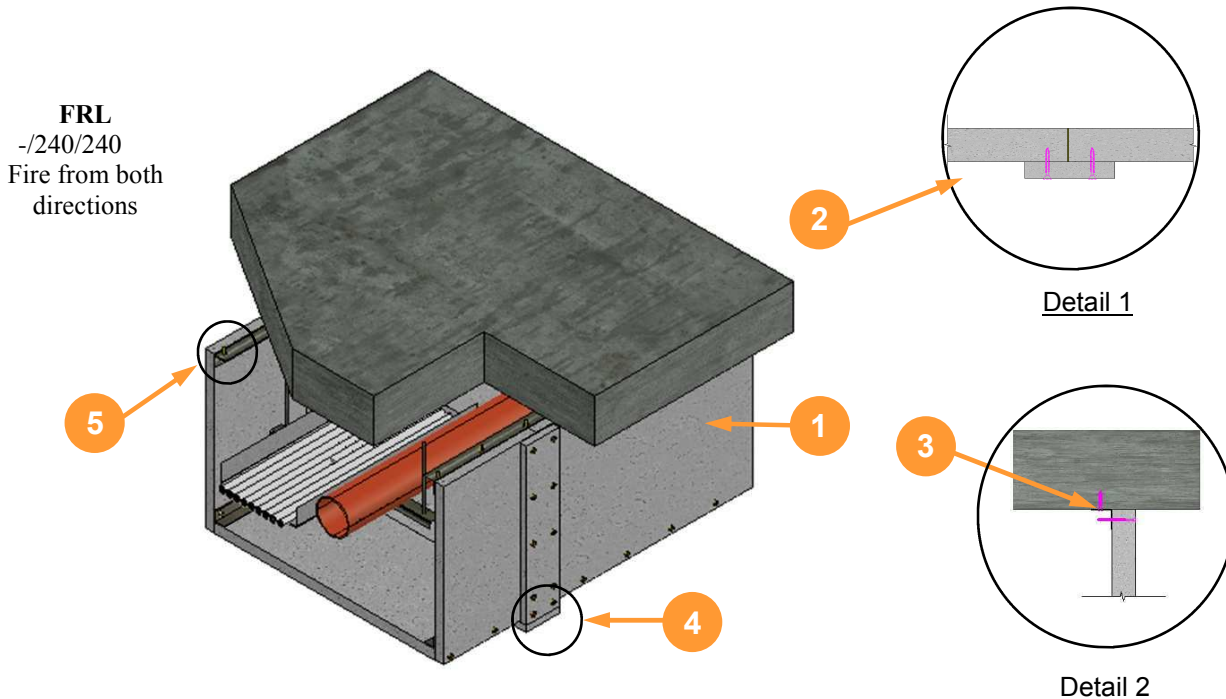

**FRL**  
-/240/240  
Fire from both directions

**Key:**

- 1 Maxilite boards, 60mm thick (or equivalent laminated thickness)
- 2 Cover Strips (Detail 1)
- 3 Steel angles, 50mm x 50mm x 0.8mm (Detail 2)
- 4 Butt joint

<b>Maxilite board</b>	60mm thick board for 4 hour fire rating. Boards are joined together using rebate or butt joints incorporating approved fire rated sealant in all joints. Boards are screw-fixed to steel angles at max. 200mm centres.
<b>Corners</b>	Corners fixed to steel angles with self tapping screws at 200mm centres.
<b>Joints</b>	Boards are joined by butt joints incorporating approved fire rated sealant. Cover strips are fixed over the joint.
<b>Cover strips</b>	20 or 30mm Maxilite or 9mm Orbit FR x 100mm wide fixed to outside of joint. Strips are secured to both sides of the joint at max. 200mm centres.
<b>Steel angles</b>	50mm x 50mm x 0.8mm (minimum size), fixed to masonry, concrete or plasterboard at max. 600mm centres and screw-fixed to boards.
<b>Fixings</b>	<ul style="list-style-type: none"> <li>- Board to board / steel angle: minimum M4 - 100mm self tapping screws at 200mm centres. Allow 10 to 15mm from edges of Maxilite board.</li> <li>- Steel angle to masonry or concrete: minimum M6 anchor bolts at 400mm centres.</li> <li>- Steel angle to plasterboard: minimum M4 - 100mm self tapping screws at 400mm centres.</li> </ul>

**Note:** Laminated boards of equivalent thickness can be used. I.e. 2x30mm

**BULKHEAD — HORIZONTAL**

## Vertical one-sided bulkheads

60mm thick Maxilite boards, up to 1500mm wide



### Self-supporting system

**FRL**  
-/240/240  
Fire from both directions

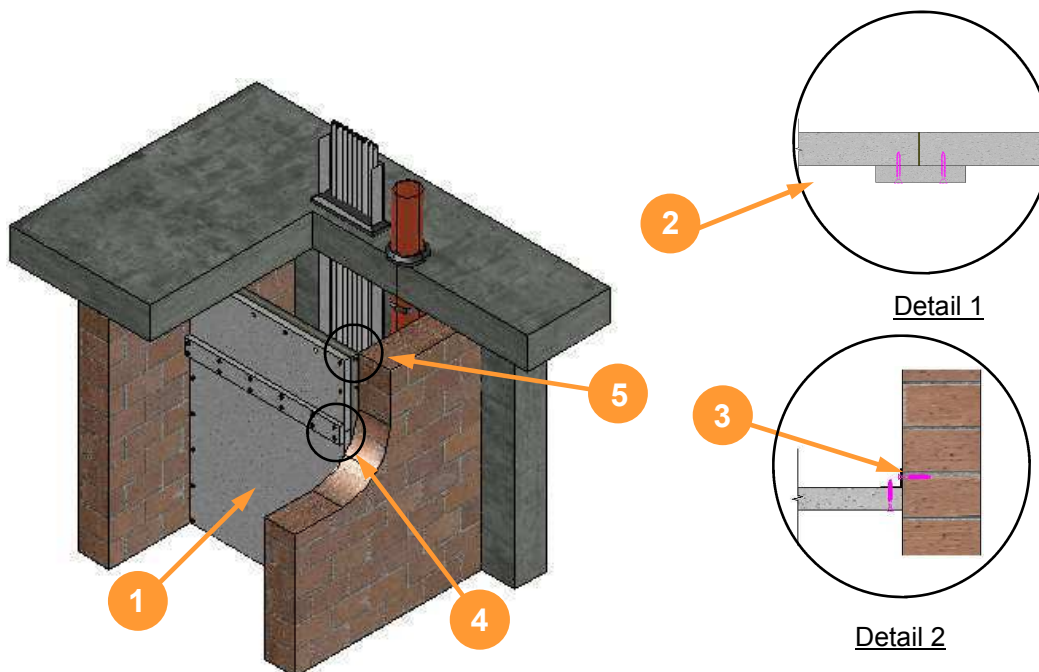

**Key:**

- 1 Maxilite boards, 60mm thick (or equivalent laminated thickness)
- 2 Cover Strips (Detail 1)
- 3 Steel angles, 50mm x 50mm x 0.8mm (Detail 2)
- 4 Butt joint

<b>Maxilite board</b>	60mm thick board for 4 hour fire rating. Boards are joined together using rebate or butt joints incorporating approved fire rated sealant in all joints. Boards are screw-fixed to steel angles at max. 200mm centres.
<b>Corners</b>	Corners fixed to steel angles with self tapping screws at 200mm centres.
<b>Joints</b>	Boards are joined by butt joints incorporating approved fire rated sealant. Cover strips are fixed over the joint.
<b>Cover strips</b>	20 or 30mm Maxilite or 9mm Orbit FR x 100mm wide fixed to outside of joint. Strips are secured to both sides of the joint at max. 200mm centres.
<b>Steel angles</b>	50mm x 50mm x 0.8mm (minimum size), fixed to masonry, concrete or plasterboard at max. 600mm centres and screw-fixed to boards.
<b>Fixings</b>	<ul style="list-style-type: none"> <li>- Board to board / steel angle: minimum M4 - 100mm self tapping screws at 200mm centres. Allow 10 to 15mm from edges of Maxilite board.</li> <li>- Steel angle to masonry or concrete: minimum M6 anchor bolts at 400mm centres.</li> <li>- Steel angle to plasterboard: minimum M4 - 100mm self tapping screws at 400mm centres.</li> </ul>

**Note:** Laminated boards of equivalent thickness can be used. I.e. 2x30mm

**BULKHEAD — VERTICAL**

## Vertical two-sided bulkheads

60mm thick Maxilite boards, up to 1500mm x 1500mm



### Self-supporting system

**FRL**  
-/240/240  
Fire from both directions

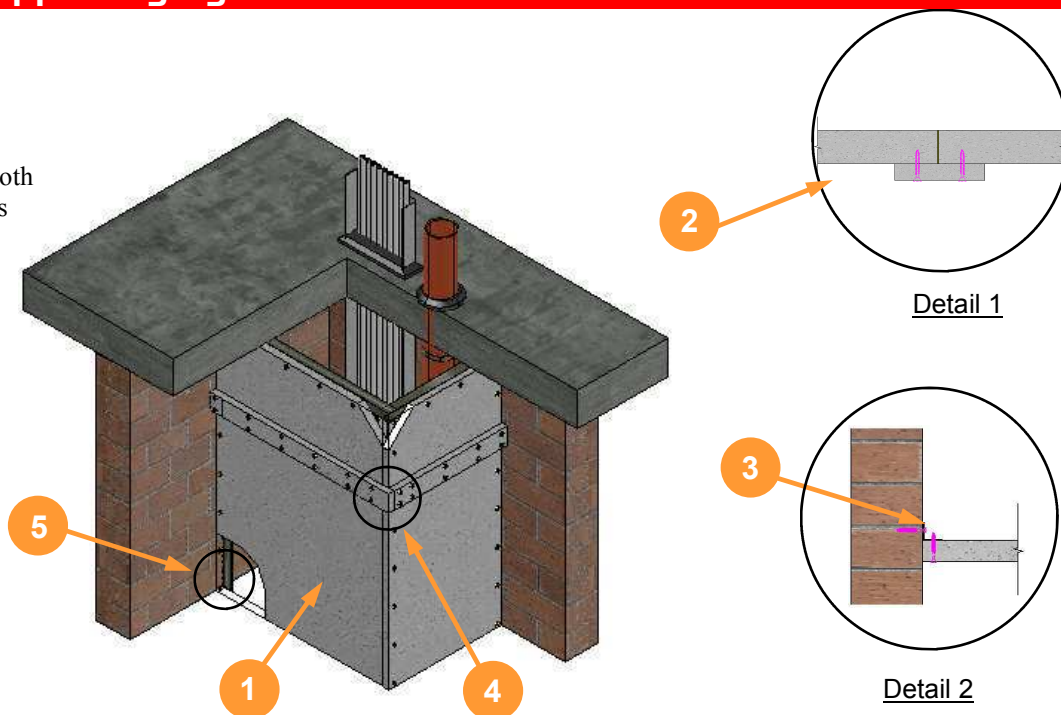

**Key:**

- 1 Maxilite boards, 60mm thick (or equivalent laminated thickness)
- 2 Cover Strips (Detail 1)
- 3 Steel angles, 50mm x 50mm x 0.8mm (Detail 2)
- 4 Butt joint

<b>Maxilite board</b>	60mm thick board for 4 hour fire rating. Boards are joined together using rebate or butt joints incorporating approved fire rated sealant in all joints. Boards are screw-fixed to steel angles at max. 200mm centres.
<b>Corners</b>	Corners fixed to steel angles with self tapping screws at 200mm centres.
<b>Joints</b>	Boards are joined by butt joints incorporating approved fire rated sealant. Cover strips are fixed over the joint.
<b>Cover strips</b>	20 or 30mm Maxilite or 9mm Orbit FR x 100mm wide fixed to outside of joint. Strips are secured to both sides of the joint at max. 200mm centres.
<b>Steel angles</b>	50mm x 50mm x 0.8mm (minimum size), fixed to masonry, concrete or plasterboard at max. 600mm centres and screw-fixed to boards.
<b>Fixings</b>	<ul style="list-style-type: none"> <li>- Board to board / steel angle: minimum M4 - 100mm self tapping screws at 200mm centres. Allow 10 to 15mm from edges of Maxilite board.</li> <li>- Steel angle to masonry or concrete: minimum M6 anchor bolts at 400mm centres.</li> <li>- Steel angle to plasterboard: minimum M4 - 100mm self tapping screws at 400mm centres.</li> </ul>

**Note:** Laminated boards of equivalent thickness can be used. I.e. 2x30mm

**BULKHEAD — VERTICAL**

## Vertical three-sided bulkheads

60mm thick Maxilite boards, up to 1500mm x 1500mm



### Self-supporting system

**FRL**  
-/240/240  
Fire from both directions

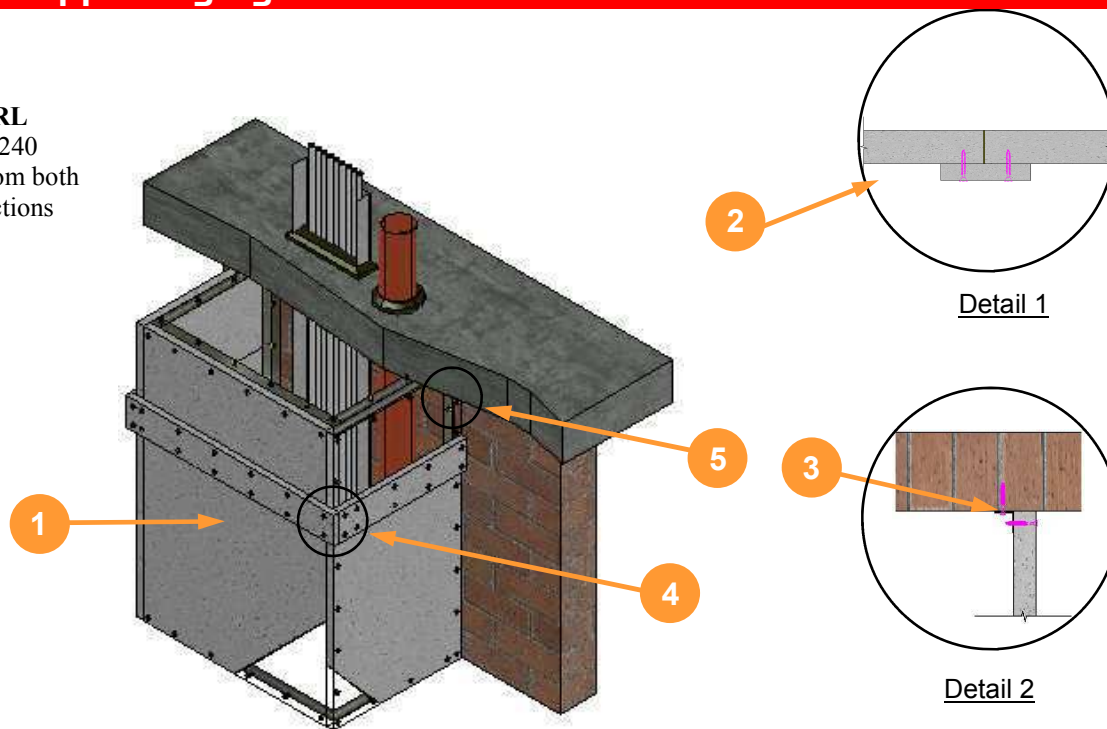

**Key:**

- 1 Maxilite boards, 60mm thick (or equivalent laminated thickness)
- 2 Cover Strips (Detail 1)
- 3 Steel angles, 50mm x 50mm x 0.8mm (Detail 2)
- 4 Butt joint

<b>Maxilite board</b>	60mm thick board for 4 hour fire rating. Boards are joined together using rebate or butt joints incorporating approved fire rated sealant in all joints. Boards are screw-fixed to steel angles at max. 200mm centres.
<b>Corners</b>	Corners fixed to steel angles with self tapping screws at 200mm centres.
<b>Joints</b>	Boards are joined by butt joints incorporating approved fire rated sealant. Cover strips are fixed over the joint.
<b>Cover strips</b>	20 or 30mm Maxilite or 9mm Orbit FR x 100mm wide fixed to outside of joint. Strips are secured to both sides of the joint at max. 200mm centres.
<b>Steel angles</b>	50mm x 50mm x 0.8mm (minimum size), fixed to masonry, concrete or plasterboard at max. 600mm centres and screw-fixed to boards.
<b>Fixings</b>	<ul style="list-style-type: none"> <li>- Board to board / steel angle: minimum M4 - 100mm self tapping screws at 200mm centres. Allow 10 to 15mm from edges of Maxilite board.</li> <li>- Steel angle to masonry or concrete: minimum M6 anchor bolts at 400mm centres.</li> <li>- Steel angle to plasterboard: minimum M4 - 100mm self tapping screws at 400mm centres.</li> </ul>

**Note:** Laminated boards of equivalent thickness can be used. I.e. 2x30mm

**BULKHEAD — VERTICAL**

## Head of Wall upgrade

60mm thick Maxilite boards, up to 1500mm high



### Self-supporting system

**FRL**  
-/240/240  
Fire from both directions

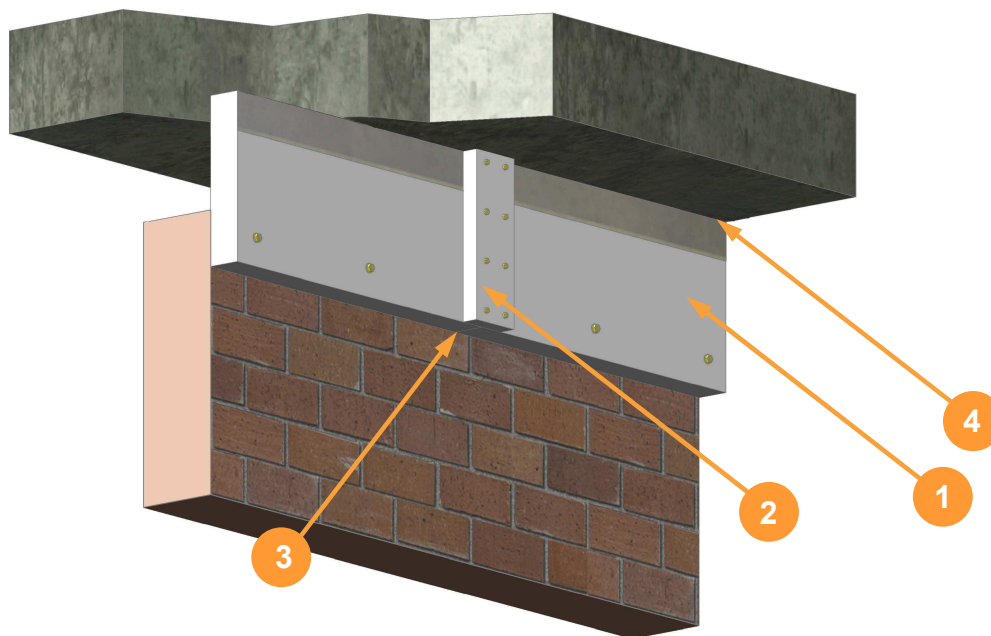

**Key:**

- 1 Maxilite boards, 60mm thick (or equivalent laminated thickness)
- 2 Cover Strips
- 3 Butt joint detail options
- 4 Control joint

<b>Maxilite board</b>	60mm thick Maxilite board for 4 hour fire rating. Maxilite boards are fixed directly to the wall but not fixed fixed to the slab above. Ensure a minimum of 10mm nominal gap is maintained between the slab and the Maxilite board to allow for building movement. Boards are joined together using butt joints details shown above (as applicable) incorporating approved fire mastic in all joints.
<b>Joints (longitudinal)</b>	Longitudinal joints between Maxilite boards consist of butt joint detail incorporating approved fire mastic. Cover strips are then fixed over the joint as shown above.
<b>Cover strips</b>	20 or 30mm Maxilite or 9mm Orbit FR x 100mm wide fixed to outside of joint. Strips are secured to both sides of the joint at max. 200mm centres.
<b>Fixings</b>	<ul style="list-style-type: none"> <li>- Board to board / steel angle: minimum M4-100mm self tapping screws at 200mm centres. Allow 10 to 15mm from edges of Maxilite board.</li> <li>- Steel angle to masonry or concrete: minimum M6 anchor bolts at 400mm centres.</li> <li>- Steel angle to plasterboard: minimum M4-100mm self tapping screws at 400mm centres.</li> </ul>

**Note:** Laminated boards of equivalent thickness can be used. I.e. 2x30mm

BULKHEAD—HEAD OF WALL